

J2

Model 55 DPS.2005



Doc: J2-55DPS2005/01

Nov 2006

J2 -55 IP65 Modulating Electric Actuator

The maintenance free **J2** electric actuator is very user friendly. It offers more standard features than any rivals in its class, and was first to the market with both multi-voltage capability with automatic voltage sensing, and an electronic torque limiter with auto-gearbox relaxing which frees the manual override when a valve is jammed. The manual override facility, with a safety power cut-out switch when operated, allows safe hand operation .

Time saving external DIN plugs allow installations to be pre-wired and eliminates the need to remove the cover to connect the actuator, which helps to reduce installation costs.

With a soft start system eliminating high motor start loads and a thermostatic anti-condensation heater that does not require a separate connection, the **J2** offers low power consumption.

The IP65 weatherproof plastic housing with stainless steel cover screws offers excellent corrosion resistance.

Local visual position indication and remote volt free end of travel confirmation are provided as standard.

The **J2** is quick and easy to install:

- ISO:5211 multi-flange F05/F07 mounting with a 17mm female double square (star) drive.
- Factory set open and closed positions at 0 and 90° (or as specified on your order).
- External electrical connections and external wiring diagram- no need to remove the cover to connect.

Note: Always read the supplied installation & operating instructions (IOM's) before use.

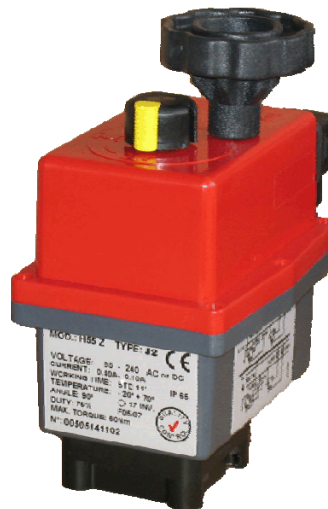

Main Features:

Multi-voltage capable with auto-voltage sensing:

J2-L55 12-48V AC/DC
J2-H55 80-240V AC/DC

Torque output::

60Nm Break

55Nm Reset

Electronic torque limiter ~ protects against valve jams

Anti-condensation heater

Manual override

All connections via external DIN plugs ~ no need to remove the cover to connect

Volt free end of travel confirmation switches

IP65 weatherproof housing

CE marked

Traceable sequential serial numbering system

Modulating function by our DPS self calibrating and auto-adjusting digital positioning system with feedback.

4-20mA control with 4-20mA output or 0-10VDC control with 0-10VDC output.

J2 -Model 55 DPS ~ Digital Positioning System

Digital Positioning System 2005 (DPS.2005)

This version uses a factory fitted internal digital positioner to control the movement of the actuator relative to a control signal, either 4-20mA or 0-10VDC, and provides an output signal as standard.

The DPS.2005 is a self calibrating and auto-adjusting unit. On first power-up, the positioner sets the span based on the motor open and closed positions. Should the actuator be over-rotated whilst in manual operation, when it is placed back in automatic function the positioner will automatically self adjust back to the original settings based on the motor open and closed positions.

The DPS.2005 arrives at the desired position and stops, eliminating hunting.

Specifications: J2 -55 DPS Electric actuator (Modulating)

Models	J2-H55-D4 80-240V AC (Iph) or DC 4-20mA J2-L55 -D4 12-48V AC (Iph) or DC 4-20mA J2-H55-D0 80-240V AC (Iph) or DC 0-10VDC J2-L55 -D0 12-48V AC (Iph) or DC 0-10VDC
Housing	IP65 Anti-corrosive Polyamide
Duty Rating	100%
Mounting	ISO5211 & DIN3337
Electrical Connection	External via DIN plugs
Torque Output	60Nm Break, 55Nm Run & re-seat
Temp Range	-20°C to +70°C
Working Time (0-90°)	10 Secs ± 10%, no load
Current 220VAC/ 110VAC	125 mA 27.5W / 400 mA 44.0W
Current 24VAC/ 24VDC	2800 mA 67.7W / 3100 mA 74.4W
Weight	2 kg

Dimensions:

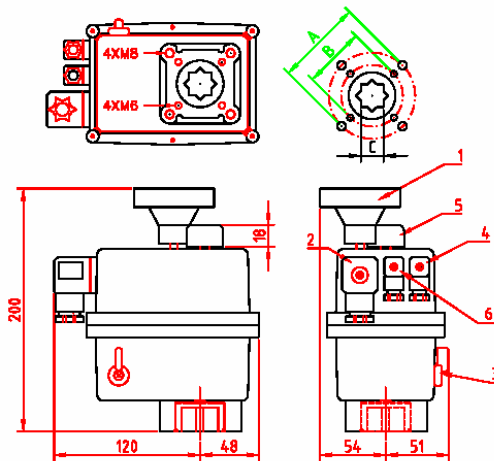

On/off, stays put on power failure:

- A/B: Multi-flange: F05/07 ISO5211
- C: 17mm double square (star)

- 1 Manual override
- 2 Power supply DIN plug
- 3 Manual override selector lever
- 4 Volt free limit switch DIN plug
- 5 Local visual position indicator
- 6 Control signal DIN plug

Wiring:

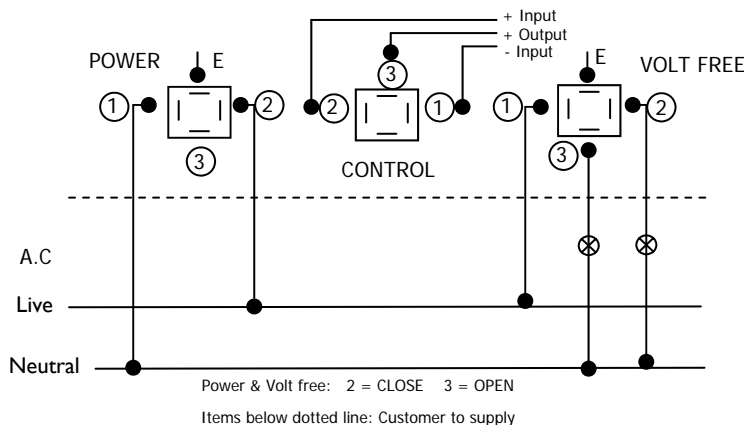

Wiring Diagram (AC or DC): 2 wire

Notes:
DIN plugs supplied with actuator.
Control signal plug rotated by 180°.

For DC wiring:

- +ve Power DIN plug Pin 2
- ve Power DIN plug Pin 3

J2

Installation, Operation & Maintenance Instructions (IOM's) Model **J2** DPS.2005



Doc: IOM.DPS.2005/02

Nov 2006

FUNCTION

The DPS.2005 is a self calibrating and auto-adjusting Digital Positioning System supplied as a factory fitted option to the **J2** range of reversible electric actuators to produce modulating functionality. The self calibrating feature senses the motor stop positions (fully open and fully closed) and sets the span at these positions, and then calibrates the steps between open and closed for either 4-20mA or 0-10VDC control signals.

Should the actuator be rotated by hand beyond these positions whilst being operated in MAN (manual operation mode) and then returned to AUTO (Automatic operation) whilst still outside the normal working quadrant as indicated by the open and closed logos moulded into the top of the actuator's cover, the DPS.2005 will auto adjust itself back into the normal working quadrant.

Hunting has been eliminated in the DPS.2005 and as soon as the actuator arrives at the required position relative to the input signal, it stops.

The DPS.2005 provides a feedback signal (in the same format as the input signal) as standard.

INSTALLATION INSTRUCTIONS

J2 actuators operate using live electricity and we strongly recommend that only qualified electricians/ electrical engineers be employed to make electrical connections as a matter of Health & Safety. They are quick and easy to connect without removing the cover, do not remove the cover without our authorisation or the warranty may be invalidated:

Check that the voltage being applied matches the voltage shown on the actuator's identification label and connect the power supply, control signal and volt free end of travel confirmation switch cables to the DIN plug(s) as per the wiring diagram affixed to the side of the actuator. Ensure that polarity of the control signal cable is as per the wiring diagram. Removing any label will invalidate the warranty. Wiring is the same for AC or DC (2 wire). If in doubt, ASK BEFORE CONNECTING.

Ensure that the rubber seal is refitted between the Din plug and base to maintain the IP65 seal, failure to fit the seals will invalidate the warranty. Do not over-tighten the plug securing screw.

Do not connect a power supply voltage in excess of 48V to the low voltage (**J2-L**) series as irreparable damage will be caused and any warranty invalidated.

If the volt free plug is not being used, blank off the cable entry to the DIN plug and leave the plug fitted to the actuator to maintain its IP65 weatherproof rating. Take care not to knock the DIN plugs as this may pull the DIN plug base away from the actuator which in turn will break the body seal and permit water to access the housing. Damage of this nature invalidates any warranty.

All **J2** actuators are supplied with volt free position confirmation switches (limit switches) that require a separate power supply to operate (rated 240V 5A) The suggested wiring as per the wiring diagram affixed to the side of the actuator shows the same voltage for the actuator being used as the power source for these switches – this is a suggestion only and any standard control voltage can be used (eg: 24VDC). The volt free end of travel confirmation switches are set slightly ahead of the motor stop positions—do not use the signal from these switches to cut the power to the motor.

Whilst the **J2** actuators can be fitted in any orientation we recommend installing the actuator vertically wherever possible. Be aware of applications where elevated temperatures could be present and allow for the possibility of heat rising – in these cases use an extended mounting kit to help dissipate the heat, and mount the actuator horizontally.

OPERATING INSTRUCTIONS

Supply a continuous (not pulse) live signal to power the actuator. The in-built heater uses this mains supply and therefore the power supply voltage should remain on at all times.

On receipt of a control input signal the actuator will move to the position relative to the input signal eg: using a 4-20mA signal, 4mA input signal closes the actuator, a 12mA signal sets the actuator at 45° and a 20mA signal opens the actuator. Each subsequent change of input signal will cause a corresponding change to the actuator position.

An output signal in the same form as the input signal is supplied as standard.

The rest positions are as per the moulded open and closed logos (see below), indicated by a local visual position indicator. NEVER move the set position of this indicator or a false position will be indicated.

In the case of control signal failure, the actuator will move to the closed position. In the case of mains power failure, the actuator will stay in the position it saw at the moment of power interruption. Should the actuator need to be operated under these circumstances, use the manual override facility, but remember to reset the selector lever in the AUTO position when the movement is completed as selection of 'MAN' cuts the power to the motor.

All **J2** actuators have an electronic torque limiter (ETL) which cuts the motor power if the applied torque exceeds the actuators rated output. To reset, cut the power, clear the cause of the excess torque (eg: valve blockage), turn the power back on and the limiter will reset allowing resumption of normal operation.

Continued on page 2 . . .

Page 2

MANUAL OVERRIDE

All **J2** actuators have a manual override facility, operated by a selector lever which disengages the motor drive when moved from AUTO (automatic operation) to MAN (manual operation). The gearbox contains planetary gears and it may be necessary to 'wobble' the selector lever whilst gently moving the manual override handle to ensure the gears disengage and re-engage. When resetting into AUTO – a positive 'click' will be felt when the gears have correctly re-engaged. A safety cut out switch, activated by the manual override selector lever, cuts the power to the motor when in the MAN position. When MAN is selected, the actuator will not operate electrically.

NEVER remove the selector lever retaining screw as this will allow the operating mechanism to become free and will cause irreparable damage to the actuator's gearbox. Removing this screw will invalidate any warranty.

When in AUTO mode, the manual override operating handle rotates on models 20 & 55 – restricting this rotation may activate the ETL. In these circumstances, switch off the power, leave a few seconds and turn back on – the ETL will automatically reset

The open and closed logos: moulded into the top cover look like this:



OPEN



CLOSED

MAINTENANCE

J2 actuators are designed to be maintenance free, the gearbox is factory lubricated for life and there are no internal parts that require maintenance.

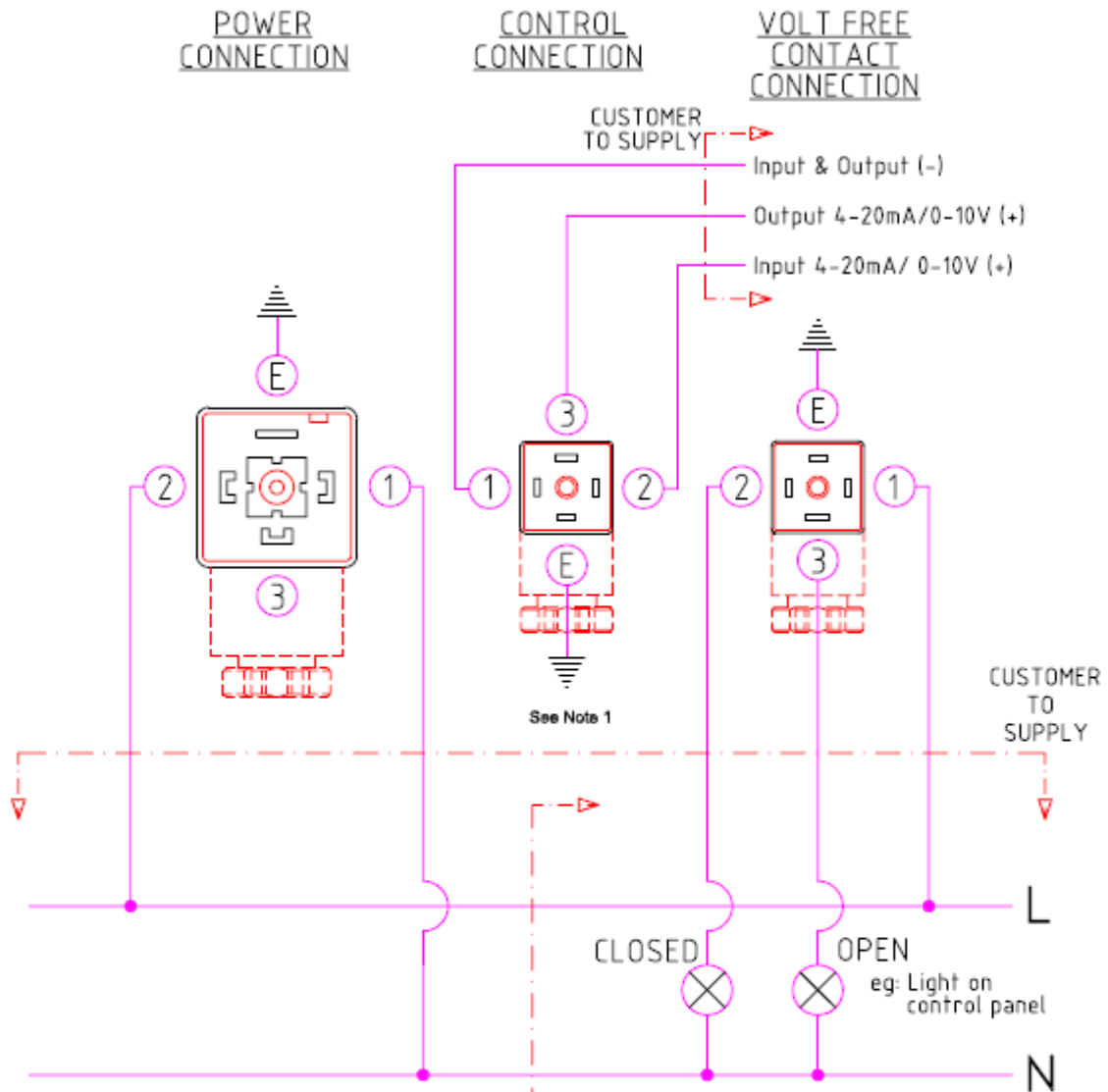

**DPS 2005
AC WIRING**

**Note 1:
DIN PLUG
ROTATED
BY 180 Deg**

**VOLT FREE CONTACTS:
Factory set at 0 & 90°
Switches rated 220V 5A**

Above wiring showing same
supply as motor is only a
suggestion.

NB: READ INSTALLATION, OPERATION & MAINTENANCE INSTRUCTIONS BEFORE CONNECTING.

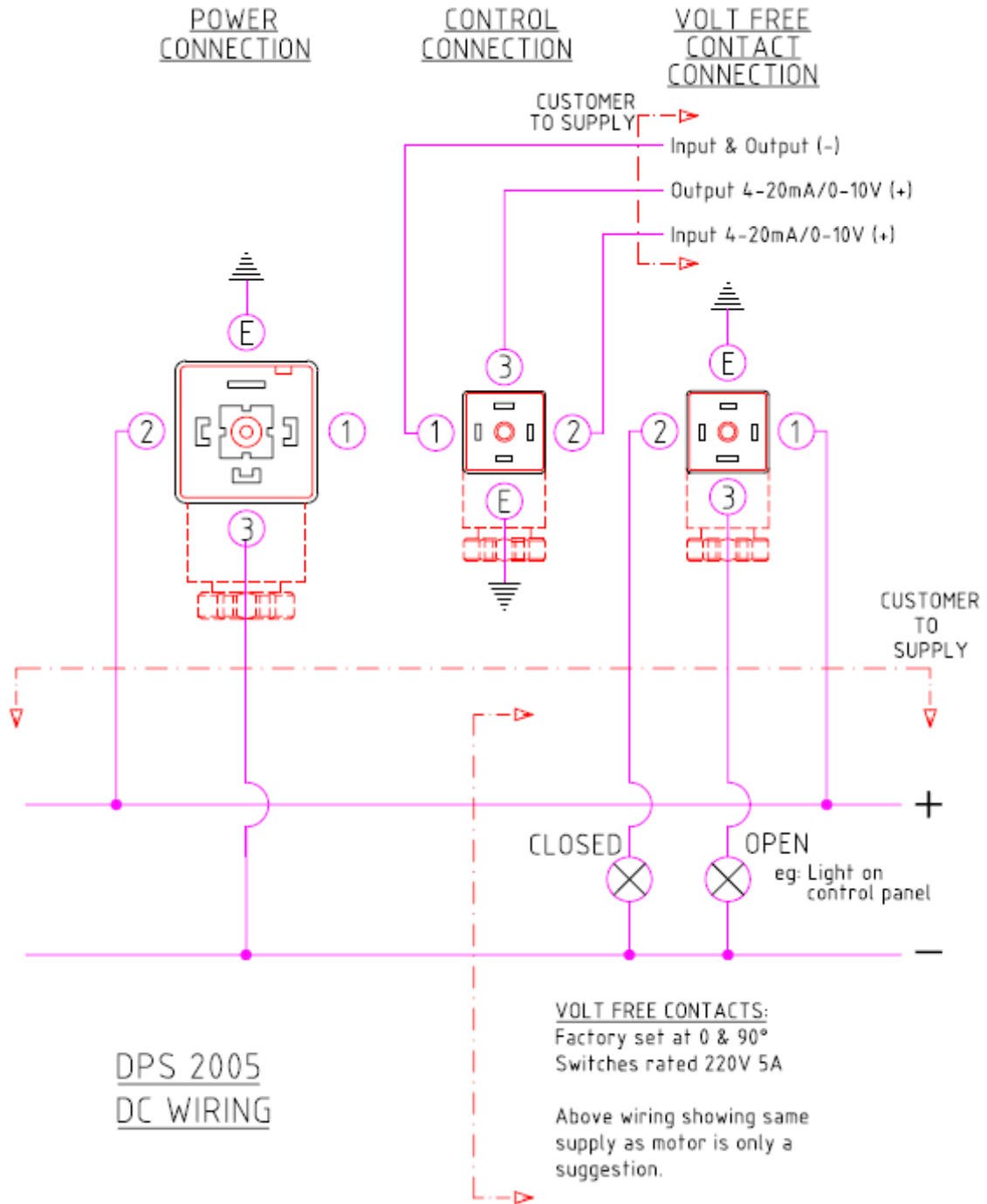

DPS 2005
DC WIRING

NB: READ INSTALLATION, OPERATION & MAINTENANCE INSTRUCTIONS BEFORE CONNECTING.