

J3CS Smart Electric Actuator Function: POWER OPEN - POWER CLOSE , FAILS 'SAFE' ON POWER FAILURE



Type: E2704S

Electric actuator direct mounted



Type: E2714S

Electric actuator fitted via kit

Main J3 Smart electric actuator features:

- LED light for continual visual actuator status feedback.
- Fully weatherproof smart industrial actuator.
- Multi-voltage 24-240V capable actuator.
- All external electrical connections, no need to remove cover .
- Selectable manual override facility.
- Thermostatic anti-condensation heater.
- Electronic torque limiter.
- End of travel switches for remote open/ closed indication.
- CE marked.
- EU manufactured by J+J.

Applications:

Potable water (but valve is not WRAS approved), oil, air and many corrosive medias, subject to compatibility with wetted parts in contact with media.

J+J Actuators sized on a maximum differential pressure of 10 bar wet service, operated at least once per day. If the intended duty differs from these parameters, or is dry (air or gas) call to check electric actuator sizing as a larger output valve actuator may be required.

Maximum working temperature of a direct mounted assembly is +70C. For higher working temperatures , consider models that have a mounting kit or TSM stem extension between the valve and actuator which uses air cooling to dissipate the rising heat from the valve away from the actuator. Should the J3CS smart actuator see more than +70C it will malfunction.

Fire safe and Anti-Static:

Fire safe ball valves use the ball to create a secondary, metal to metal seal in the event of an external fire, which prevents flow of media when the internal soft seals have melted. They are approved following a burn test where the pressurised ball valve is literally burned in a fire pit, passing the test if the leakage rate is within acceptable pre-defined limits. The anti-static device connects the ball and stem to the body to prevent the build up of electrical static within the ball valve.

Specifications:	
Actuator housing	UV Protected Polyamide
Supply voltage range	24-240V AC or DC
IP Rating	IP67
Actuator temp limits	-20 to +70°C
Assembly temp limits	E2704S +70°C
	E2714S +130°C
	E2724S +100°C
Valve body	CF8M (Cast 316SS)
Valve ball	316SS
Valve seats	RPTFE
Valve Pressure rating	UTI 1" 138 bar at ambient temp
	1 1/4" - 2" 103 Bar at ambient
Valve temp limits	-20 to +200°C
Size range	1/4" to 2"

Ball valve information:

Reduced bore 3 piece construction, providing full unrestricted flow and a very low pressure drop across the valve. Designed for automation with integrally cast ISO5211 actuator mounting platform. Thick wall body construction with encapsulated body bolts allow higher working pressure.

Turning the ball through 90° fully opens the valve, turning back through 90° fully closes the valve and isolates the flow. End connections are threaded BSP female. NPT ends are available as an option.

Typical CV Values

Size	1/4"	3/8"	1/2"	3/4"
CV	8*	8*	8	12
Size	1"	1 1/4"	1 1/2"	2"
CV	32	56	82	120

J3CS FAILSAFE ELECTRIC ACTUATOR

Power open, power close, fails to pre-set position on loss of external power. Typically fails closed, but can be set to fail open. BSR Failsafe conversion kit pre-installed by J+J.

How this electric 1/4 turn valve works (on-off):

Electrically operated valves are driven by a motor and gearbox. On receipt of a continuous voltage signal the motor runs and, via a gearbox in the J+J smart electric actuator, rotates the valve stem. The motor stops at the desired position (usually 0° or 90°) by internal cams striking micro-switches. The smart valve actuator remains in this position, with the voltage still applied continuously, until switched and a continuous voltage reversing signal is applied, which runs the motor in the opposite direction, reversing the rotation until separate set of internal cams strike separate set of micro-switches.

Options:

It is possible to change the J3CS actuator's function by installing user friendly plug and play function conversion kits. These will provide the following alternative functions:

Failsafe Modulating J3CS Actuator

Movement of the J3CS actuator is proportional to an input control signal, typically 4-20mA or 0-10V, but by installing our DPS (Digital Positioning System) user friendly plug and play kit, it will fail to the desired pre-set position on loss of external power. There are also options for how the J3CS modulating reacts to loss of the control signal as follows:

Configuration options:

- 1) Closes on loss of control signal, or on loss of power
- 2) Opens on loss of control signal, or on loss of power
- 3) Stays put on loss of control signal



DPS Modulating plug & play kit can be installed with the BSR failsafe kit to create failsafe modulating function.

Electrical Connection - Wiring of DIN Plugs

J3CS FAILSAFE WIRING

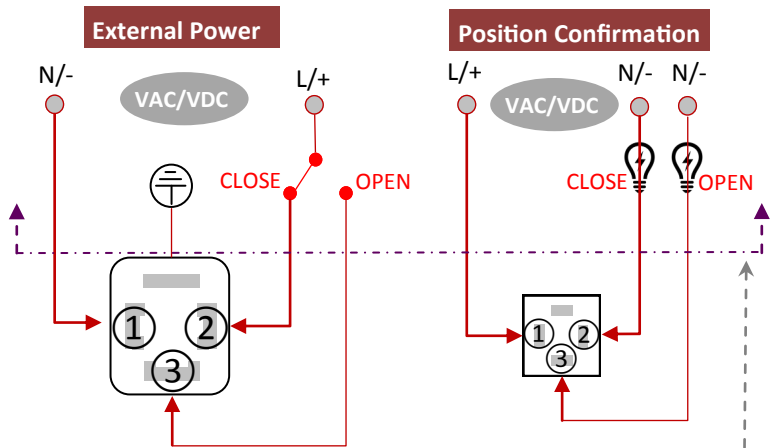

Note: Above line above is customer supplied

In J+J electric actuators all electrical connections are made externally using the external DIN plugs supplied with the actuator. There is no need to remove the valve actuator's cover to connect electrically. There are no terminals internally to connect to.

Pre-installed Plug & Play Function Conversion Kit:



BSR Failsafe plug & play kit (already installed by J+J in the failsafe version)

How the BSR (Battery 'Spring Return') system works:

The user friendly BSR failsafe function plug and play conversion kit adds an industrial NiCad rechargeable battery and PCB to the standard power open, power close J3CS actuator. The electric actuator continues to operate power open, power close, and whilst doing so, the battery is constantly trickle charged to keep it fully charged.

When external power is lost, a switch in the BSR PCB draws internal power from the battery to send the J3CS to the desired pre-set 'safe' position, if not already in that position.

Type: **E2704S** Actuator direct mounted to valve

Typical Dimensions:

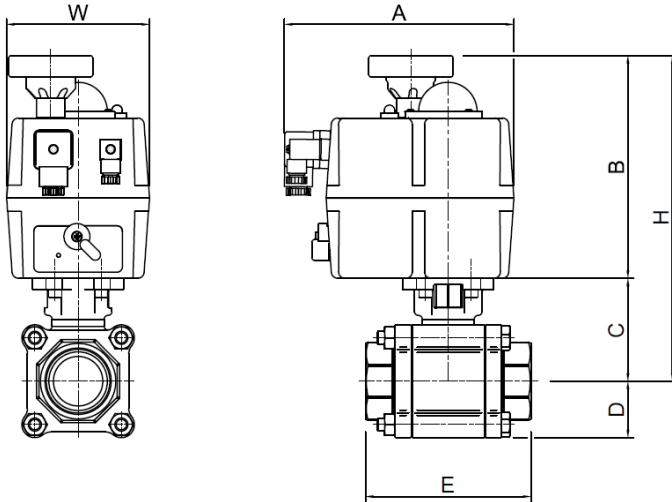

E2704S Dimensions remain unchanged for all versions
- On-off, failsafe, modulating and failsafe modulating

	Model	A	E	H	W	Kilos
≤1/2"	20	177	75	214	110	2.3
3/4"	20	177	73	214	110	2.8
1"	20	177	85	216	110	3.5
1 1/4"	20	177	105	230	110	4.3
1 1/2"	35	177	111	212	110	6.1
2"	35	177	127	228	110	7.1

Type: **E2714S** Actuator fitted to valve via a bracket and drive adapter

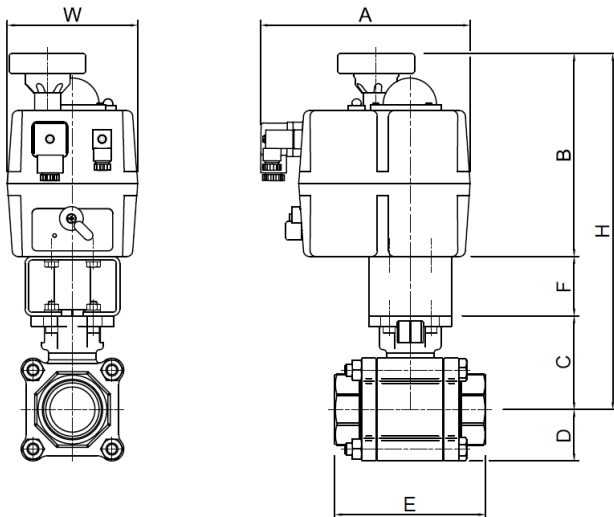

E2714S Dimensions remain unchanged for all versions

	Model	A	F	E	H	W	Kilos
≤1/2"	20	177	50	75	264	110	2.2
3/4"	20	177	50	73	264	110	3.0
1"	20	177	50	85	268	110	3.7
1 1/4"	20	177	50	105	280	110	4.5
1 1/2"	35	177	50	111	262	110	6.3
2"	35	177	50	127	278	110	7.3